

A measured step forward™

Operations & Maintenance Manual

**1700 Series - Models 1720,
1730 & 1740**



Contents

- Description
- Principle of Operation
- Installation – General
- Installation – Electrical
- Operation
 - Start-up
 - Capacity Adjustment –Manual Control
 - General
 - Adjustment, Model 1740
 - Adjustment, Model 1720/1730
- Maintenance
 - Diaphragm and Check Valves
 - Lubrication
 - Pressure Relief Valve
 - Back Pressure Valve
- Troubleshooting
- Safety Precautions

Description

The Model 1720, 1730 and 1740 Prosuperb metering pumps are highly accurate over a wide range, and ideally suited for pumping corrosive or toxic liquids because only static seals are used.

The hydraulically actuated diaphragm positively returns to a fixed reference position at end of each stroke, producing accurate delivery. A simple capacity adjustment, which can be made whether pump is running or stopped, controls hydraulic fluid displacement without changing stroke length.

The pre-stressed elastomeric diaphragm enables operation at low NPSH or high suction lift.

Fig. 1-Model 1730 (Left) and Model 1740 (Right) Proportioning Pumps shown with floor stand base. Pumps are also available with flat base for customer-supplied mounting pad. Ball check valves with replaceable seats, or poppet valves with elastomer seals on Model 1730 and 1740 are easily removed for inspection and maintenance without disconnecting process piping. Model 1720 utilizes column check valves with NPT connection.

Electric motors are standard foot mounted.

All Equipment Design And Application Data Shown Herein and Related Know-how Are Confidential And The Property Of JESCO AMERICA CORPORATION, NO Use Or Disclosure Thereof May Be Made Without Our Written Permission.

Principle Of Operation

(Refer to fig. 2 and 3)

The pump is electric motor driven thru a right angle worm gear speed reducer. The speed reducer is self-lubricated and incorporates seals to totally isolate its lubricant from the pump hydraulic system. The pump housing is mounted on the speed reducer housing with a fixed eccentric attached directly to the reducer output shaft. The eccentric design is such that duplex pump plungers are phased 180° apart. A connecting rod attaches to the piston-plunger assembly (1), converting the rotary motion to reciprocating motion. Downward movement of the plunger results in pressurization of the hydraulic fluid, which causes the pre-stressed diaphragm (2) to expand and displace liquid out of the pumping chamber through the discharge check valve (3).

The plunger has an axial flow passage from the bottom, which terminates at a radial passage (4) at the upper end of the plunger. Downward motion of the plunger displaces hydraulic fluid in the chamber below the plunger. Effective pumping displacement is controlled by the position of the capacity setting slide (5), which is positioned vertically by a capacity control rod. As long as the radial flow passage is open (because it is above the slide) liquid displaced by the plunger passes upward into the hydraulic atmospheric reservoir and no process liquid is pumped.

As the plunger continues downward, the radial flow passage is closed by the slide, capturing the hydraulic fluid which expands the diaphragm causing process liquid to be discharged through the discharge check valve (3). When the plunger reaches its bottom position and then begins to move upward, the pre-stressed

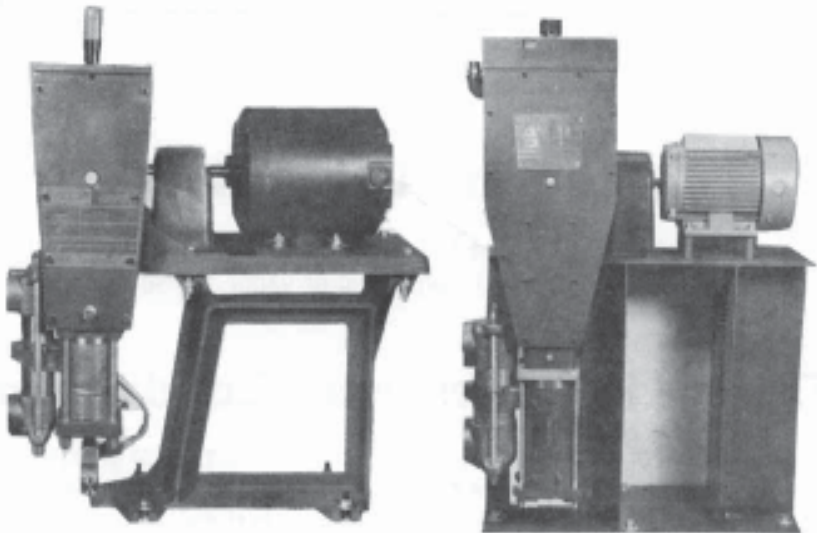

Fig. 1 - Model 1730 (left) And Model 1740 Proportioning Pumps Shown With Standard Base and Mounted on Customer-Supplied Concrete Pad

diaphragm (2) retracts toward its original position. The resulting vacuum created in the pumping chamber results in process liquid being drawn into the chamber through the suction check valve.

On each stroke, the diaphragm returns to a fixed reference point provided by a rigid diaphragm support, which insures continuous accuracy by maintaining proper phase positions of diaphragm and plunger.

The plunger continues to the topmost point of its travel and then begins another pumping cycle. Both the hydraulic pumping chamber and the liquid pumping chamber are designed to eliminate entrained vapor on each stroke. This is accomplished on the hydraulic side by the ability of the vapor to pass upward through the plunger and be vented to the hydraulic reservoir. In the process liquid chamber, the flow passages slope upward to the discharge check valves without high point traps.

To vent and fill the hydraulic system automatically on each stroke, the upper capacity slide stop is adjusted so that the radial flow passage in the plunger is uncovered for a portion of the plunger travel.

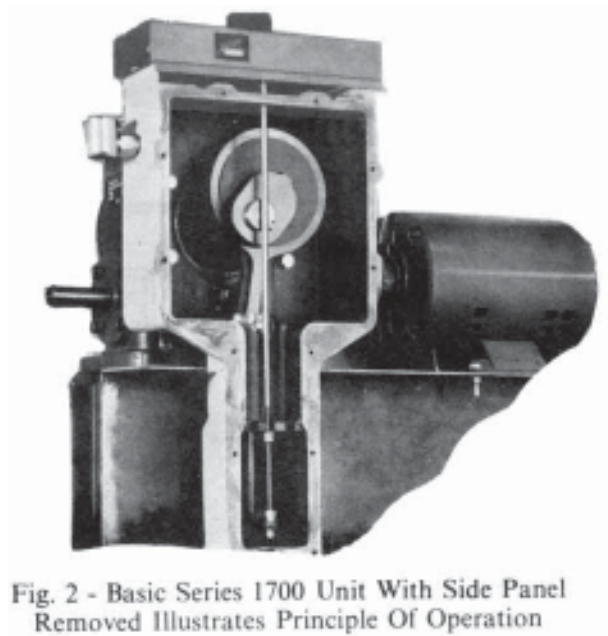

Fig. 2 - Basic Series 1700 Unit With Side Panel Removed Illustrates Principle Of Operation

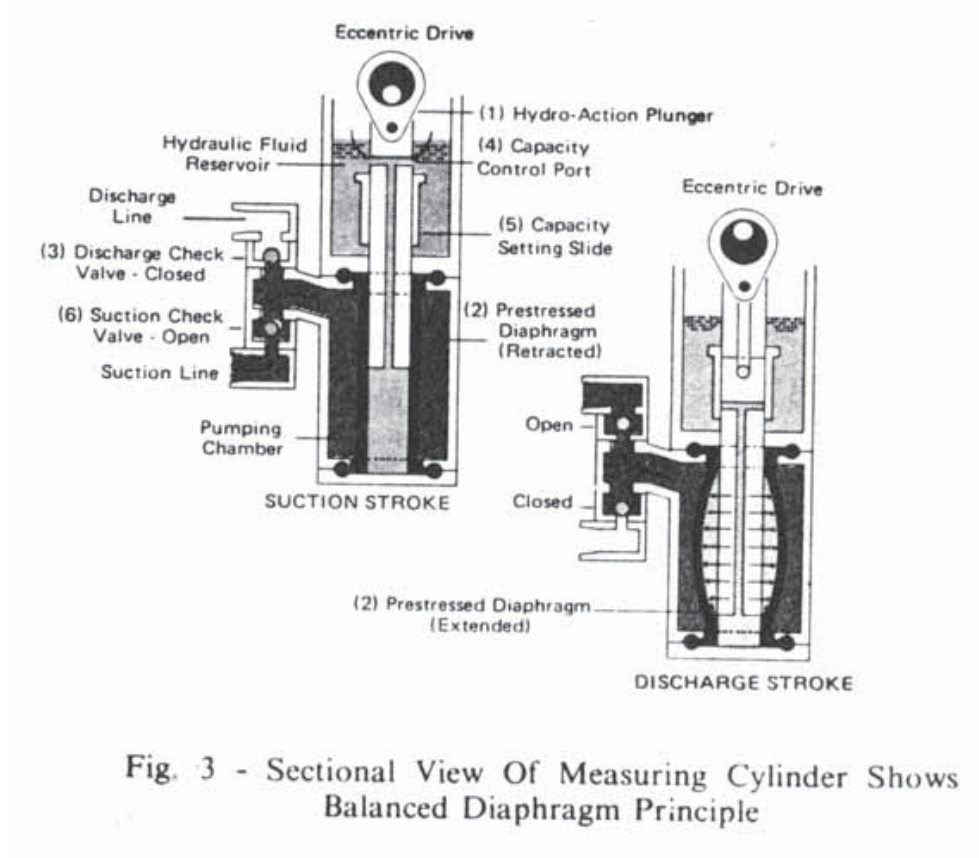

Fig. 3 - Sectional View Of Measuring Cylinder Shows Balanced Diaphragm Principle

Installation – General

1. All piping must be well supported. AVOID STRAIN AT PUMP SUCTION AND DISCHARGE CONNECTIONS.
2. Flush and blow out all piping before connecting to pump. Use pipe dope only sparingly; and on male threads only. After piping has been flushed and blown out, remove pump suction and discharge elbows, and thread connecting pipe or fittings into elbows – DO NOT THREAD PIPE INTO ELBOWS WHILE ATTACHED TO PUMP. Reassemble elbows and check valves to pump. Flow direction arrows on check valve bodies must point upward
3. SUCTION LINE SIZE MUST NOT BE LESS THAN PUMP CONNECTIONS and should be as short and straight as possible, and with minimum possible number of elbows, tees, and other fittings.
4. Install shut-off valves to facilitate pump maintenance operations: CAUTION: Do not install a shut-off valve between pump discharge and system relief valve.
5. Install suction line strainer to prevent foreign matter from entering pump.
6. Process system must be protected from excessive pressure by a separate relief valve. Particular care should be taken to assure adequate factor of safety in plastic piping systems
7. Installation of a by-pass valve to allow re-circulating process liquid back to supply tank, and to facilitate venting air at start-up is desirable. However, if pump is equipped with built-in backpressure valve, a vent valve, provided on pump cylinder, must be used for venting. (Vent and built in back pressure valve not available for Model 1720).

Installation - Electrical

1. Check pump motor nameplate for electrical characteristics and power supply requirements.
2. Electrical service and motor control system must be in accordance with applicable codes and local ordinances.
3. Lead-in wires must be of adequate size to prevent excessive voltage drop.
4. A current-responsive thermal overload protective device must be installed to prevent motor burnout under sustained overload.
5. Pump motor rotation may be in either direction.

OPERATION

Start-Up

1. The speed reducer is factory-filled with proper amount and type of oil. However, recheck oil level before starting pump.
2. Using oil furnished with pump and by means of oil cup at top of pump housing, fill housing to center of oil level window.
3. Set capacity control at maximum delivery setting
4. Open suction and discharge line valves. With flooded suction, allow pump and piping to fill by gravity.
5. Open by-pass valve to tank. Jog pump motor two or three times to lubricate internal moving parts; then start pump.

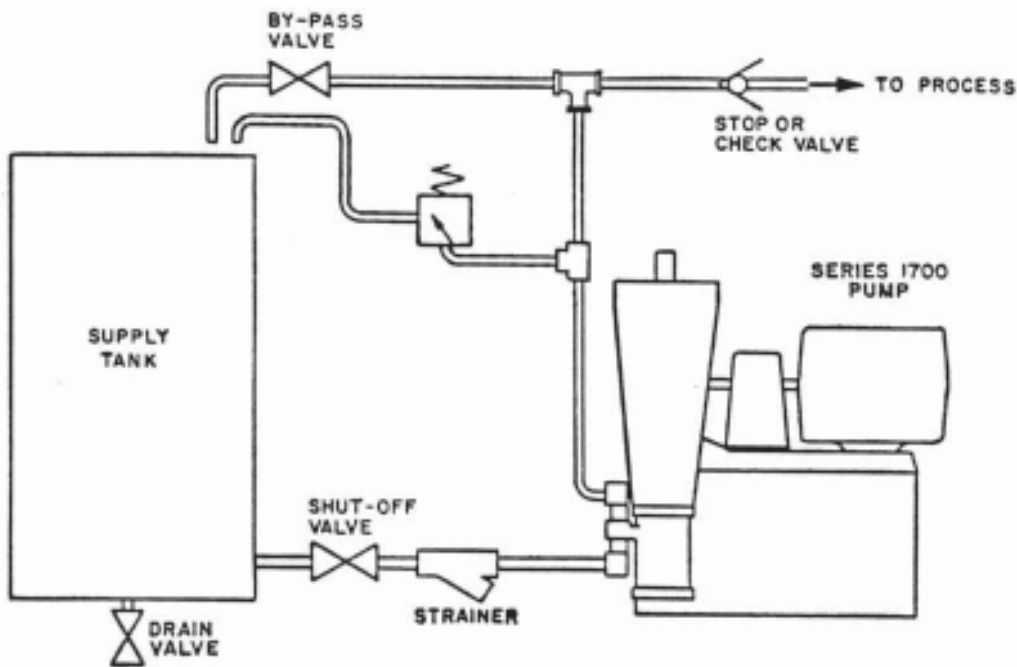

Fig. 4 - Typical Installation

- In the cylinder "ear" between check valves is a normally closed vent valve. Back off the setscrew by 1-1/2 turns to enable valve to function—venting to atmosphere during discharge stroke and closing during suction stroke. Reseat the setscrew when liquid discharges—pump is primed. Note: A 1/4 in. hole below the vent valve enables insertion of tubing if it is desired to discharge process liquid to a container.
- When there is suction lift, discharge will not begin for some time, depending on height of lift, line size and pump capacity. Dry operation during priming will not harm pump. Wetting check valves balls when possible with water or process fluid prior to start-up will speed up the priming operation.
- Let process fluid recirculate back to tank until discharge is free of air bubbles. Close by-pass valve when ready to start normal operation.

Capacity Adjustment – Manual Control, General

Pump stroke length is fixed. Delivery rate is controlled by vertically positioning capacity setting slide (Fig. 3) by means of the knob at top of pump housing. Maximum delivery occurs when the slide is at its uppermost position. Relative setting is indicated below the knob.

Compressibility of hydraulic and process fluids affect delivery rate. The pump is designed to deliver rated capacity at rated maximum pressure.

Actual operating conditions may necessitate further field adjustment. If discharge pressure is less than rated maximum, or process liquid has a lower coefficient of compressibility, pump delivery curve will be displaced upward (Fig. 5). If the coefficient is higher, curve will be displaced downward. In either case, delivery curve linearity is not affected.

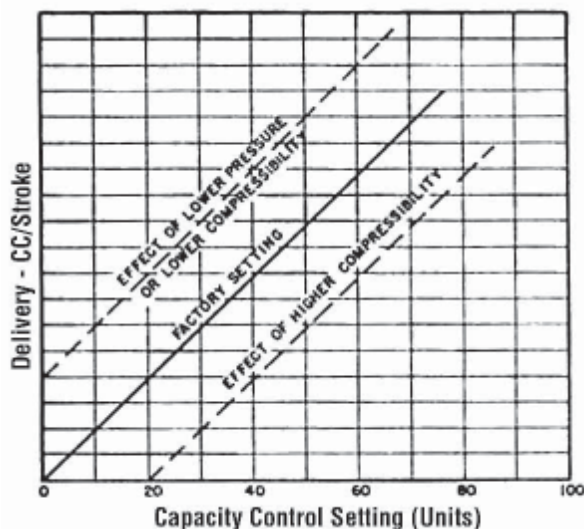

Fig. 5 - Typical Delivery Curve of Series 1700 Pumps

Capacity Adjustment, Model 1740

Regardless of method, make adjustments with pump operating at normal system pressure.

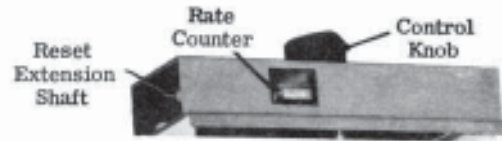

Figure 6 - Manual Stroke Adjustment for Model 1740

Method A

- With pump operating at normal system pressure adjust control knob until flow just ceases.
- By turning reset extension shaft at left side of top cover, reset counter to 000. Repeat step 1 to recheck.
- Adjust control knob to a counter setting of 50 then slowly reduce setting. Delivery should stop at 000; if not, repeat steps 1,2 and 3.
- Check delivery characteristics.

Method B

- With pump operating at normal system pressure, check delivery at two or more capacity settings.
- Plot delivery versus setting on linear graph paper with delivery as the ordinate and capacity setting as the abscissa, with zero values of both at the intersection.
- Draw a curve through measured values and note the point of intersection on the abscissa.
- Adjust control knob to counter reading in step 3.
- By turning extension shaft at left side of top cover, reset counter to 000.
- Recheck delivery and replot graph. Zero delivery should now occur at zero counter reading.

Capacity Adjustment, Model 1720 and 1730

Adjustments should be made with pump operating at normal system pressure.

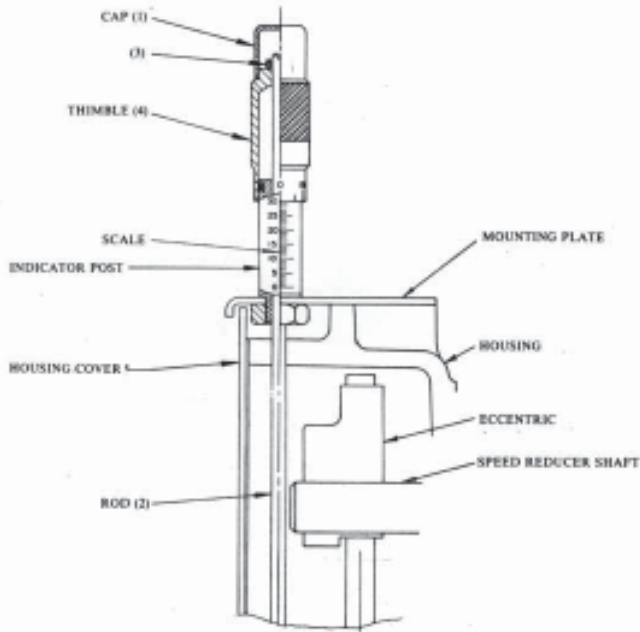

Fig. 7 - Model 1720/1730 Manual Stroke Adjustment Assembly

Method A

1. With pump operating at normal system pressure, adjust micrometer control until flow just ceases. Stop pump.
2. Remove cap (1) from control knob.
3. Hold control rod in position by use of a screwdriver inserted in slot at end of rod (2)
4. Loosen hex nut (3) above micrometer thimble.
5. Still holding rod in position, rotate micrometer barrel until setting is zero.
6. Tighten hex nut and replace cap. Check delivery characteristics. Zero setting should result in no delivery.

Method B

1. With pump operating at normal system pressure, check delivery at two or more capacity settings.
2. Plot delivery versus setting on linear graph paper with delivery as the ordinate and capacity setting as the abscissa, with zero values of both at the intersection.
3. Draw a curve through measured values and note the point of intersection on the abscissa.
4. With pump stopped, adjust capacity setting to the value determined by the intercept of the delivery curve on the graph abscissa.
5. Remove plastic cap (1) from control knob.
6. Hold control rod with screwdriver in slot at top of rod (2).

7. Loosen hex nut (3) above micrometer thimble (4).
8. Holding rod in position, rotate micrometer barrel until setting is zero.
9. Tighten hex nut and replace cap.
10. Recheck delivery. Plotted curve should now pass through zero intercept.

Maintenance

Diaphragm and Check Valves

Replace the diaphragm and O-Ring check valve seals annually unless experience indicates more frequent need.

Replacing Diaphragm (Refer to Fig. 8a or 8b)

1. Shut off pump and close valves in suction and discharge lines. Drain suction line and discharge line if possible.
2. Drain pump housing hydraulic oil. Remove both check valve clamp studs. Slide check valves from between elbows and cylinder. Remove nuts from cylinder mounting studs. Remove one stud and rotate cylinder to clear pipe connections. Lower measuring cylinder assembly and remove. If assembly resists removal, manually rotate motor coupling to raise plunger and provide clearance.
3. Remove end cap and push diaphragm support from center of diaphragm. Clamp cylinder in vise and remove diaphragm from cylinder by doubling in lower flange and pushing diaphragm through bore with a blunt ended rod.

NOTE: Avoid damaging diaphragm – do not use any sharp ended tool such as a screwdriver, when removing or installing a diaphragm.

4. Wash all parts thoroughly before reassembling.
5. Install new diaphragm by doubling in lower flange and pushing diaphragm through cylinder bore with a blunt ended rod. A light coat of oil on the diaphragm flange and cylinder bore will facilitate assembly.

NOTE: Rotate diaphragm so that high point of air venting shoulder is adjacent to flow passage in cylinder. This can be determined by reference to the material code letter on the upper face of the diaphragm. See Fig. 8a.

6. Insert diaphragm support tube. Reinstall end cap and assembly cylinder to pump housing in reverse procedure to that in Step 3.
7. When reassembling the liquid end of the pump after any maintenance or repair operation during which disassembly had been performed, care must be taken to properly tighten the stud nuts, which are holding the cylinder end cap and check valve assembly.

Lubricate the threaded portion of the studs, which will hold the nuts and tighten the nuts with a torque wrench in the following manner;

- a. Hand-tighten all nuts.
- b. All further tightening is to be done using a torque wrench.
- c. Tighten cylinder end cap nuts in the following pattern: 1, 3, 2, 4.

- d. Tighten nuts to the following values 1720-1730-1740 pump cylinder studs: Tighten per pattern to 20 ft-lbs. on first round. Follow pattern on succeeding rounds, increasing to 25, 30 and final 35 ft-lbs.*

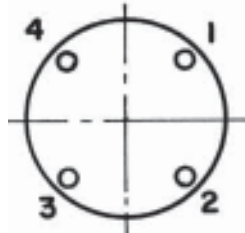

1730-1740 check valve studs; Tighten per pattern to 20 ft-lbs. on first round.

On plastic valve assemblies tighten to final 25 ft-lbs. on second round.

On metal valve assemblies tighten to 25 ft-lbs. on second round and final 30 ft-lbs.

*1730 with 5/16" diam. Studs – tighten to 10 ft-lbs.

***Ball Type Check Valves (Refer to Fig. 9)**

*Applicable to Models 1730 & 1740. Model 1720 check valves are not serviceable and should be replaced as a whole. Refer to Fig. 10.

Examine valve balls and seats, and replace O-rings at the same time that diaphragm is replaced.

- To disassemble check valves, push on ball guide with blunt rod. Examine ball and seat. If ball has any indentation, replace it. There must not be any irregularities on ball seating surface. NOTE: Metal seats are reversible. To provide a new seating surface turn the seat over, unless it has been damaged by flow erosion and/or corrosion.

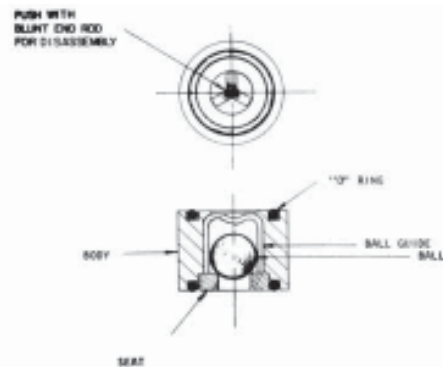

Fig. 9 - Check Valve Assembly Model 1730 and Model 1740 Units

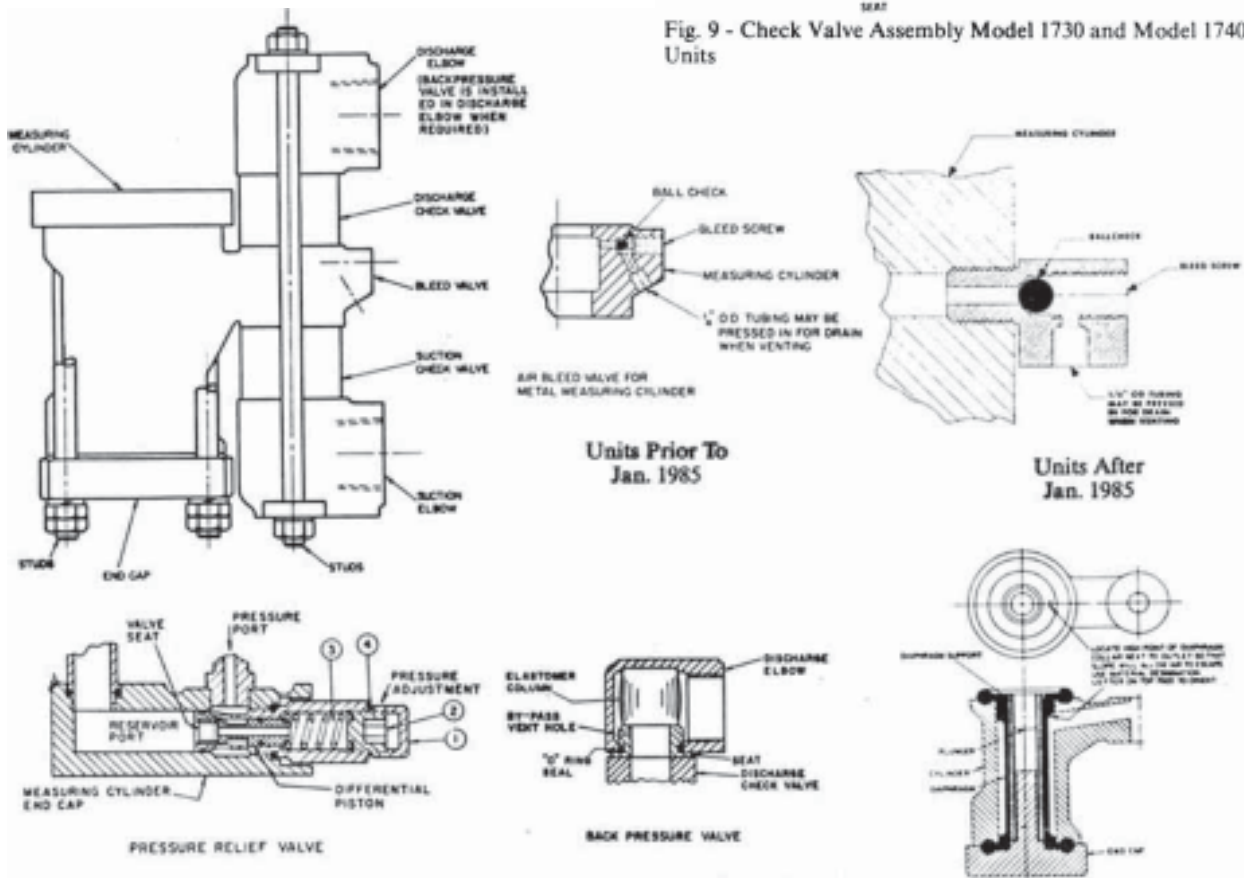

Fig. 8a - Components Of Liquid Ends (Metal) For Models 1730 & 1740

2. Install new O-rings and reassemble.
3. Insert check valves between cylinder "ear" and suction/discharge elbows. ARROWS ON CHECK VALVE BODIES MUST POINT UPWARD.
4. Center valve bodies on base. Reassemble and tighten clamp studs.
5. If no additional service operations are to be performed on pump, be sure to refill housing with oil to proper level before start-up.

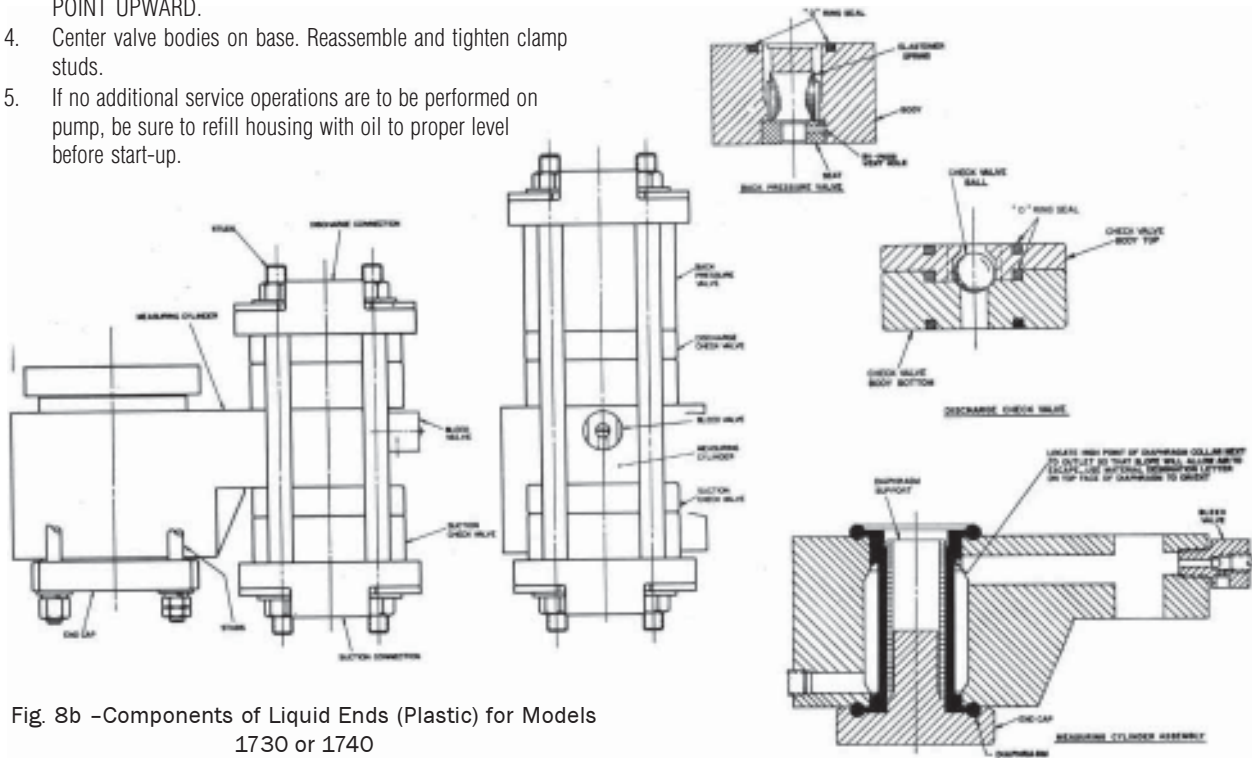

Fig. 8b - Components of Liquid Ends (Plastic) for Models 1730 or 1740

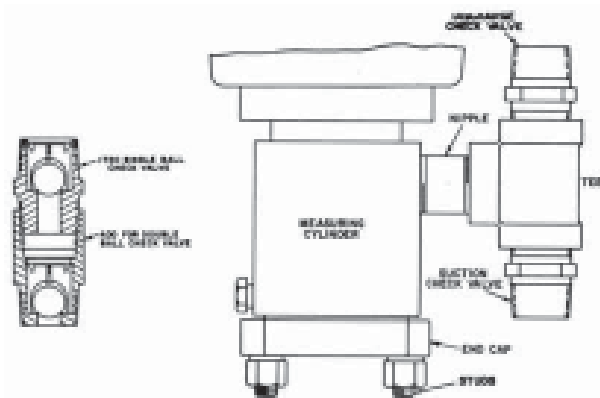

Fig. 10 - Components of Liquid Ends for Models 1720

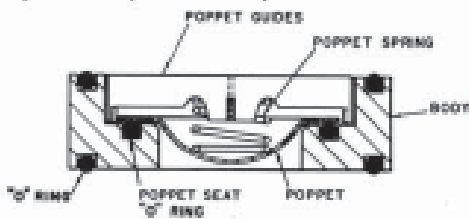

Fig. 11 - Poppet Type Check Valve Assembly Model 1740 Pumps with 1-3/8" and 2" Measuring Cylinders.

Poppet Type Check Valves (Refer to Fig. 11)

Examine valve parts, and replace O-rings at the same time that diaphragm is replaced.

1. To disassemble check valves, carefully push on poppet – DO NOT DISTORT. Examine body, and seating surface for wear and/or corrosion. Check spring condition. Replace worn or corroded parts.
2. Install new O-rings and reassemble.
3. • Insert check valves between cylinder "ear" and suction/discharge elbows. ARROWS ON CHECK VALVE BODIES MUST POINT UPWARD.
4. Center valve bodies on base. Reassemble and tighten both clamp studs.
5. If no additional service operations are to be performed on pump, be sure to refill housing with oil to proper level before start-up.

Lubrication

Drain and replace speed reducer oil after first 240 hours of operation. For ambient temperatures above 50°F, use SAE #90 gear oil. Thereafter, change oil every 2 or 3 months for continuous operation; every 6 months for 8 hours per day operation. FILL ONLY TO OIL LEVEL PLUG, NEVER HIGHER.

NOTE: Do not operate pump when hydraulic fluid temperature is below 32°F.

Drain and replace pump hydraulic oil after first 240 hours of

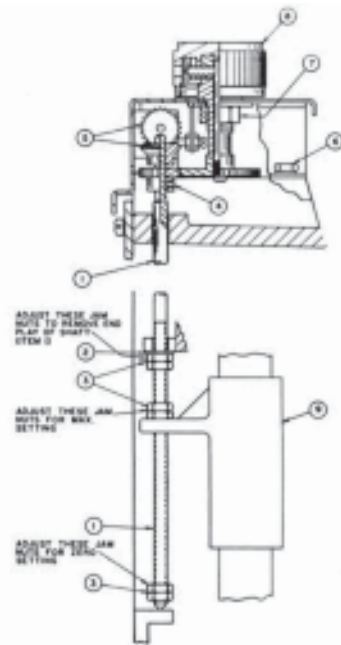

Fig. 12 - Model 1740 Manual Stroke Adjustment Assembly (Old Style)

operation. For ambient temperatures above 50°F, use SAE #10W/30 motor oil for MS Service such as Sunoco Special, Shell X-100, or Texaco-Havoline. FOR TEMPERATURES BELOW 50°F, USE A MIXTURE OF 1 PART FUEL OIL (DIESEL FUEL OR KEROSENE) AND 3 PARTS #10W/30 MOTOR OIL FOR MS SERVICE. Thereafter, follow same schedule of changes as for speed reducer. HYDRAULIC OIL LEVEL SHOULD BE AT MIDDLE OF OIL LEVEL WINDOW.

Capacity Setting Slide Adjust., Model 1740 (Old Style)

Refer to Fig. 12. Pump delivery is adjusted by positioning the capacity setting slide. If pump service requires disassembling slide and control rod, READJUSTMENTS MUST BE MADE AT REASSEMBLY. Stop positions must be correct at zero and maximum settings to avoid incorrect delivery or physical damage to pump.

1. With oil drained and housing cover removed, insert capacity adjusting rod (1) thru hole in housing. Install washer (2) and 4 jam nuts (3) well up on rod. Thread rod thru ear of capacity setting slide and install 2 jam nuts (3) at end of rod.
2. Rotate motor coupling until eccentric is exactly at bottom dead center.
3. Insert a 0.008 in. diameter wire thru slot in plunger. Then, with rod (1) bottomed on housing, rotate it to raise slide (9) until it just holds wire in position.
4. Keep rod bottomed and raise lower jam nuts until snug against bottom of ear on slide (9). Tighten nuts finger tight.

5. With rod bottomed, adjust upper jam nuts until washer (2) bears against slot in housing and yet allows free rotation of rod (1) with very slight endplay. Lock nuts in position; then rotate motor coupling to raise plunger and remove wire in step 3.
6. Raise lower jam nuts 1/6 turn (one flat). Lock nuts in position.
7. Rotate motor coupling until eccentric is exactly at tip dead center.
8. Insert a 0.083 in diameter wire (#45 drill) thru slot in plunger. Rotate rod until slide contacts wire.
9. Adjust middle two jam nuts snugly against top of ear on slide (9). Lock nuts in position; then rotate rod to lower slide slightly and remove wire.
10. Rotate reducer output shaft thru one revolution and make sure that plunger assembly moves freely thru one revolution. If there is interference, repeat steps 2 thru 10.
11. Slide spur gear (4) and miter gear (5) onto rod (1). Do not tighten setscrews.
12. Mount top cover assembly and loosely assemble screws (6).
13. Position cover assembly to align miter gears. Raise miter gear (5) on rod (1) to freely mesh with miter gear on counter shaft with minimum backlash, and tighten setscrew. Hold cover assembly in correct position and tighten mounting screws (6).
14. Position spur gear (4) for fullface mesh with drive gear at bottom of knob shaft, and tighten setscrew.
15. Check assembly for free running. Spur gear mesh can be adjusted by loosening clamp nut (7) and positioning driveshaft assembly for free mesh.
16. Rotate control knob (8) until slide (9) stops against lower jam nuts on rod (1). Reset counter to 000 by turning extension shaft at left side of top cover.
17. Reinstall pump housing cover gasket and cover. Tighten cover screws to 50 in. lb. torque.
18. Fill housing with oil to proper level.
19. For final adjustment procedure, refer to "Capacity Adjustment, Model 1740".

Capacity Setting Slide Adjust. Model 1720/1730/1740

Refer to Fig. 13. Pump delivery is adjusted by positioning the capacity setting slide. If pump service requires disassembling slide and control rod, READJUSTMENTS MUST BE MADE AT REASSEMBLY. Stop positions must be correct at zero and maximum settings to avoid incorrect delivery or physical damage to pump.

1. With oil drained and housing cover removed, insert capacity adjusting rod (1) thru hole in housing. Install washer (2) and 4 jam nuts (3) well up on rod. Pass rod thru ear of capacity setting slide and install 2 jams nuts (3) at end of rod.
2. Rotate motor couplings until eccentric is exactly at bottom dead center.
3. Insert a 0.008 in. diameter wire thru slot in plunger. Lift capacity setting slide until it retains wire through plunger.
4. With rod (1) bottomed on housing raise lower jam nuts until snug against lower side of slide.
5. Rotate motor coupling to raise plunger and remove wire in step 3.
6. Keep rod (1) bottomed and raise lower jam nuts 1/6 turn (one flat). Lock nuts in position.

7. Lock capacity setting slide to rod by tightening upper jam nuts (3). Rod should be free to rotate but without any appreciable vertical lost motion.
8. Rotate motor coupling until eccentric is exactly at top dead center.
9. Insert a 0.060 in. diameter wire (#53 drill) thru crossdrilled hole in plunger.
10. Lift rod (1) and capacity setting slide assembly until slide retains wire through plunger.
11. Adjust upper two jam nuts (3) to stop against housing.
12. Lower rod to its bottom position and remove wire.
13. Rotate reducer output shaft thru one revolution and make sure that plunger assembly moves freely thru on revolution of this eccentric. If there is interference, repeat steps 2 thru 10.
14. Assemble mounting plate (4), indicator post (5), O-ring (6), and nut (7).
15. Screw thimble (8) onto rod until lower edge of thimble lines up with zero line on scale. (Rod should be bottomed on housing.) Lock thimble to rod with jam nut (9). Install cap (10).
16. Reinstall pump housing cover gasket and cover. Tighten cover screws to 50 in. lbs. torque.
17. Fill housing with oil to proper level.
18. For final adjustment procedure, refer to "Capacity Adjustment, Model 1720/1730".

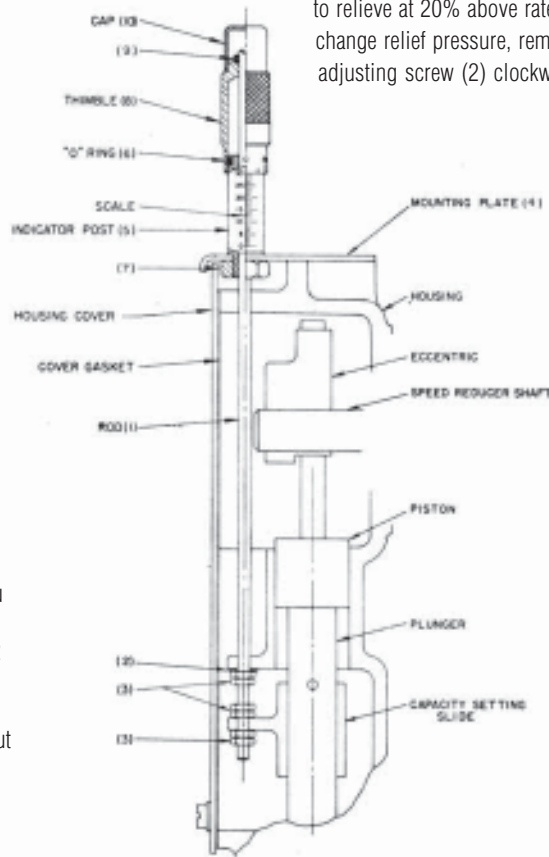

Fig. 13 - Model 1720/1730/1740 Manual Stroke Adjustment Assembly

to relieve at 20% above rated pressure on pump nameplate. To change relief pressure, remove cap (1) and, with Allen wrench, turn adjusting screw (2) clockwise to increase relief pressure, and vice versa. Replace cap. Be sure metal gasket (4) is in good condition and reversed when put back in place. Pressure acts upon the annular area between the outside edge of the piston and the smaller diameter at the seat end of the piston, producing a net force tending to move the piston away from the seat. When this force exceeds spring seating force, valve opens and relieves pressure back to hydraulic fluid reservoir.

NOTE: Air in valve spring chamber (3) will cause loud buzzing and rather violent pump vibration synchronous with pump stroke when valve relieves. Spring chamber must be completely full of oil.

Non-Adjustable Pressure Relief Valve – (Refer to Fig.15)

This is a non-adjustable spring-loaded relief valve which is assembled in a bypass circuit between the cylinder bottom cap and the hydraulic system reservoir. The setting of the valve is pre-selected to provide relief protection of 20% above the rated pressure on the pump nameplate.

Back Pressure Valve – Optional (Refer to Fig. 8a or 8b)

When pump is furnished for low system pressures, a backpressure valve may be provided to prevent overfeeding and erratic operation. The valve is an elastomer column (of same material as diaphragm and seals) compressed inside the discharge elbow between the top counter bore and an O-ring sealed seat provided at top of discharge check valve. This valve is not adjustable.

NOTE: Backpressure valve seat has a by-pass vent hole and cannot be used as an antisiphon valve.

Pressure Relief Valves

Series 1700 pumps may be provided with relief valves to provide protection of the pump and driving motor from damage due to excessive discharge pressure which may be caused by an obstruction or closed valve in the discharge line.

The pressure relief valve provided with a Series 1700 pump may be one of two types: (a) Adjustable and (b) Nonadjustable.

Adjustable Pressure Relief Valve – (Refer to Fig. 14)

NOTE: Minimum set pressure 200psig

This is an adjustable, differential piston pressure type valve which is assembled in the measuring cylinder bottom cap. It is factory-set

Trouble Shooting

Problem	Possible Cause	Recommended Action
Failure to Start	Electrical circuit open	Check electrical circuit to motor.
Pump Stops Running	Electrical circuit open	Check electrical circuit to motor.
Pump Stops Delivery	<ul style="list-style-type: none"> a. Pressure relief valve bypassing b. Dirty or worn check valves c. Low hydraulic oil level d. Diaphragm rupture 	<ul style="list-style-type: none"> a. Check pump discharge pressure, reduce to pump maximum or below. b. Clean or replace check valve balls and seats c. Fill to proper level. d. Check for hydraulic oil in process liquid or process liquid in hydraulic reservoir which indicates diaphragm failure. Replace diaphragm.
Erratic Delivery		(See cause & correction for "Pump stops delivery")
Underfeed	<ul style="list-style-type: none"> a. Pump vapor bound b. Dirty or worn check valves c. Improper capacity setting slide adjustment d. Excessive suction lift e. Suction line obstruction f. Hydraulic oil too heavy 	<ul style="list-style-type: none"> a. Allow pump to operate at low pressure through bypass valve to eliminate vapor. b. Clean or replace check valve balls and seats. c. Readjust per "Capacity setting slide adjustments" herein. d. Rearrange system to decrease lift. e. Clean and/or flush suction line. f. Refill with lighter oil as specified herein under "Lubrication".
Overheating Speed Reducer	<ul style="list-style-type: none"> a. Low oil level b. Oil too heavy 	<ul style="list-style-type: none"> a. Fill to proper level. b. Refill with lighter oil as specified herein under "Lubrication".
Overheating Pump Housing	<ul style="list-style-type: none"> a. Low oil level b. Oil too heavy 	<ul style="list-style-type: none"> a. Fill to proper level. b. Refill with lighter oil as specified herein under "Lubrication"

Safety Precautions

The diaphragm-metering pump is designed to pump various liquids into pressurized systems. By nature, the application of these pumps may present circumstances under personal hazards can exist. All personnel who may have occasion to install, operate or maintain these pumps should be provided with the opportunity to read this instruction manual or be advised of its contents. Awareness of potential hazards can prevent accidents and injury.

Danger from Liquids Handled

The liquid being pumped may be hazardous due to corrosivity, acidity or toxicity. Suitable personal protective equipment should be used at all times to protect from liquid or vapor. Consult your employer.

Damage from Pressurized Liquid

All systems containing liquid and/or air under pressure present the potential for unexpected discharge of liquid in a violent manner. In operation and servicing of the pump, all parts of the pump and attached piping which contain liquid should be treated cautiously until it is known with certainty that they have been depressurized and drained.

Danger from Electrical Hazard

Since these pumps are electric motor driven and may include electric components, the hazard of electrical shock can exist. Installation and wiring of electrical components should be in accordance with the applicable codes.

Operational Hazards

To avoid personal injury, the following guidelines should be adhered to:

1. Do not operate pump with coupling and shaft guards removed.
2. Do not operate pump with electrical component enclosures not in place.
3. When venting cylinders or piping during start up, liquid will be discharged under pressure. Suitable caution should be taken to avoid contact with the liquid and to avoid spillage or spraying of liquid.
4. Any leakage or spillage of liquid should be cleaned up without delay.

Safety

1. Before operating pump or attempting to service, become familiar with contents of Instruction Manual
2. Observe all precautions established by plant safety procedures.
3. Observe all chemical handling instructions provided by the chemical supplier and/or plant regulations.
4. Do not operate pump with closed valves in suction and/or discharge lines
5. Do not paint over or remove nameplates, labels or tags
6. In disassembly of pump, precautions should be taken for the possibility that a diaphragm rupture may have allowed pumped liquid to enter the hydraulic oil system.
7. If motor replacement is required, be certain that speed is the same as the original motor.
8. If pump is to be used for other than original service, first ascertain that pump is suitable for new conditions (pressure and material compatibility with liquid to be pumped).
9. Establishment of and adherence to a regular maintenance program can prevent problems by early detection of unusual conditions. Such a program should include checking for unusual noise, overheating and wetness indicating the initial stage of leakage.

This page intentionally left blank.



Accessories



Chemical Feed Systems

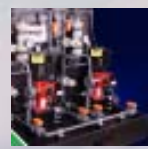

Measuring and Control Technology



Transfer Pumps

Metering Pumps